

antares

5-axis CNC machining centers,
passage in Z from 500 mm



CMS is part of SCM Group, a technological world leader in processing a wide range of materials: wood, plastic, glass, stone, metal, and composites. The Group companies, operating throughout the world, are reliable partners of leading manufacturing industries in various market sectors, including the furniture, construction, automotive, aerospace, ship-building, and plastic processing industries. SCM Group coordinates, supports, and develops a system of industrial excellence in three large, highly specialized production centers employing more than 4,000 workers and operating in five continents. SCM Group: the most advanced skills and know-how in the fields of industrial machinery and components.

CMS SpA manufactures machinery and systems for the machining of composite materials, carbon fiber, aluminum, light alloys, plastic, glass, stone, and metals. It was established in 1969 by Mr Pietro Aceti with a vision of offering customized and state-of-the-art solutions, based on the in-depth understanding of the customer's production needs. Significant technological innovations, originating from substantial investments in research and development and take-overs of premium companies, have enabled constant growth in the various sectors of reference.



CMS Plastic Technology produces numerically-controlled machining centres and thermoforming machines for the working of plastic materials, offering technologically advanced solutions. The brand originates from the winning synergy between the technical-industrial expertise in thermoforming of the historical company Villa, established in 1973, and CMS' historical know-how in milling. Thanks to constant investments in research and innovation, CMS Plastic Technology is recognized as unique partner for the whole process: from thermoforming to trimming to the realization of models and moulds, ensuring maximum productivity.

CMS Plastic Technology is in the forefront of manifold sectors, such as: automotive, aerospace, earth-moving machinery, caravans, buses, railway industry and production of bathtubs.

antares

APPLICATIONS	4-5
ANTARES / ANTARES TR TECHNOLOGICAL BENEFITS	6-7
ACCESSORIES	8-11
ANTARES DIMENSIONS AND TECHNICAL DATA	12-13
CMS CONNECT	14
CMS ACTIVE	15
SERVICE	16-17
THE RANGE	18-19



APPLICATIONS



automotive | marine industry | furniture



consumer goods | mass transport | aerospace



Unparalleled.
New.
Innovative.
Quality.
Ultra.
Effective solutions.

The **UNIQUE** cnc machines.

5-axis CNC machining centers, passage in Z from 500 mm

ANTARES / ANTARES TR

TECHNOLOGICAL BENEFITS

5-AXIS HIGH SPEED CNC MACHINING CENTER WITH MONOBLOC STRUCTURE FOR PLASTIC PROCESSING

Its compact design easily fits into any production environment, while still benefitting from the large working envelope.

- The monobloc structure ensures stiffness and accuracy throughout its lifetime.
- Maximum accessibility to the working area for piece loading / unloading by manual or automated systems.
- Full acoustically-lined enclosure to contain dust and to reduce the noise generated by the machining operation.

Antares is also available with rotating working tables (TR). This model can offer reduced overall dimensions for the same working areas and an easier integration in the production flow. The rotating table (TR) is managed by an NC axes to ensure speed, accuracy, position repeatability and reliability.



KEY BUYER BENEFITS

- + **Produce more and better: today and tomorrow** The advanced design of the structure, a result of CMS' research center, and the technical solutions adopted guarantee rigidity and precision over time so that the high finish and accuracy of the workpieces remains a constant feature of your production over the years. The accuracy of ANTARES CMS boasts the industry's best-in-class performance in its category: +23% machining precision and accuracy.
- + **Zero downtime** The maximum accessibility to the working area for workpiece loading and unloading operations, even with automated systems, makes production lean, handy and quick; moreover, the availability of a version provided with two working areas and rotary table enables zeroing equipping and loading/unloading times.
- + **Dust? no problem!** The machine has been designed to better manage dust, chips and noise produced during machining. The total enclosure and the outfit of a wide range of accessories and systems expressly designed for the various types of materials and productions ensures the safety of the operators, cleanliness of the working environment and production efficiency.

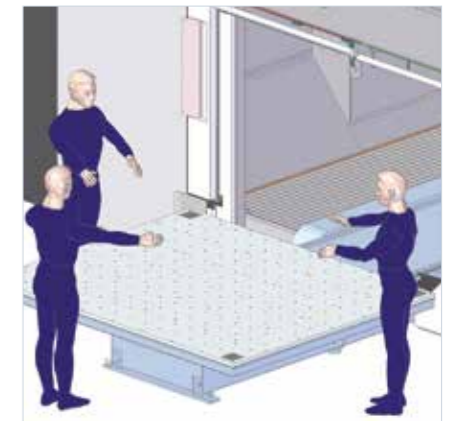

Rotary table: easy access to the work table in total safety

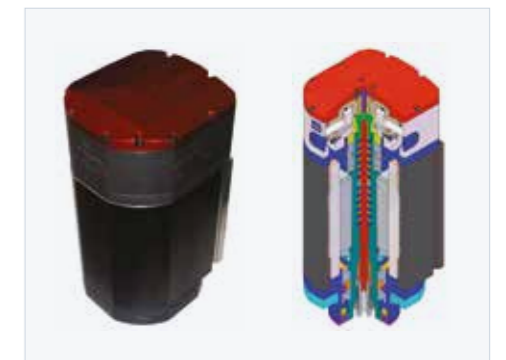

Wide range of electrospindle designed and manufactured inside SCM Group.

ACCESSORIES



Cold air gun

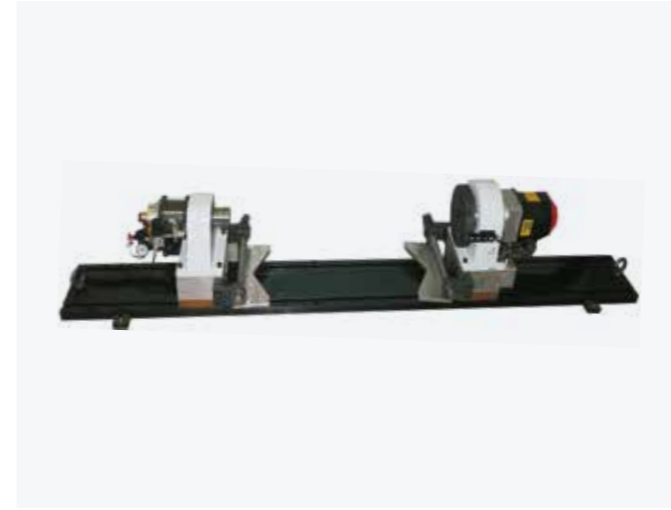

NC controlled - stock and tailstock group

Tool changer magazine; 16 stations



Dust suction hood



Electronic touch probe



Oil mist unit

ACCESSORIES



Vacuum / air connections



Steel table with T slots

Rotary axis alignment with laser device for measuring tool length and diameter



Aluminum vacuum table with steel T slots



Soundproof full enclosure with pneumatic opening for the loading with the crane.



Aluminum vacuum table

Dust extraction vents



Multilayer phenolic vacuum table

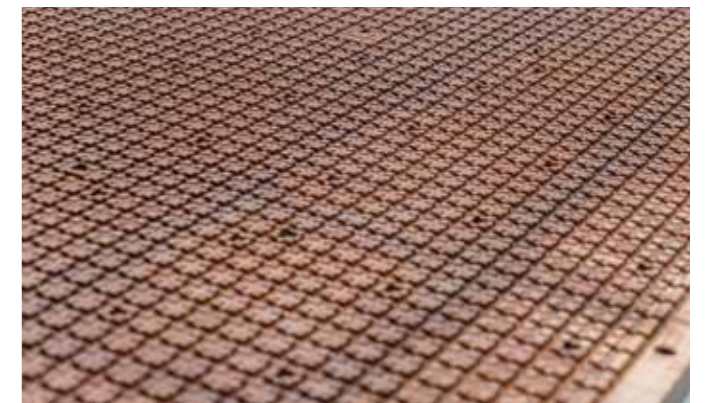

ANTARES

OVERALL DIMENSIONS & TECHNICAL DATA

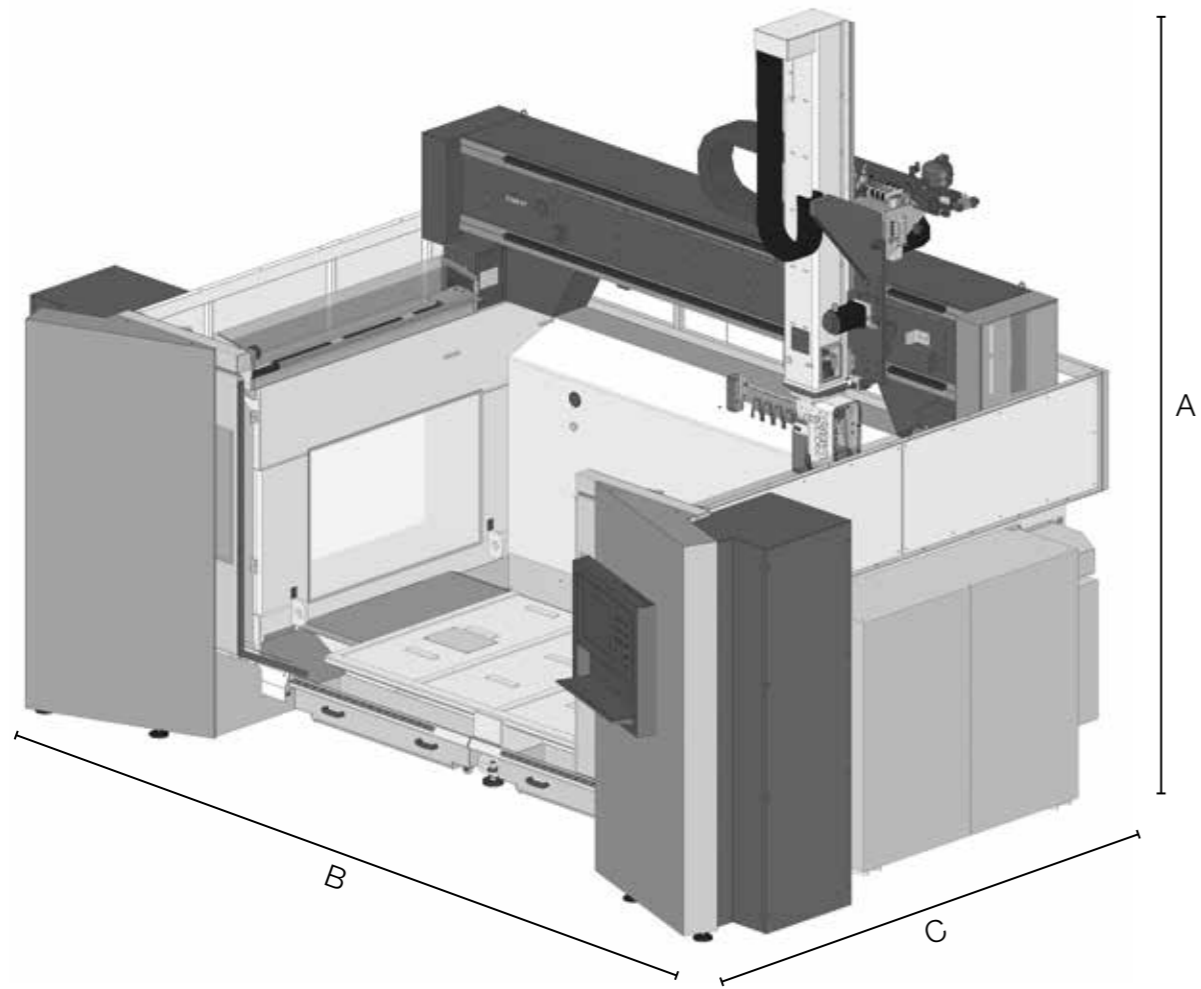

ANTARES: ENCUMBRANCE			
A	Z AXIS STROKE		
	4250/4500*		
B	X AXIS STROKE		
	2600 5500	2600 K Version 7300	
C	Y AXIS STROKE		
	1500 3600	1700 3850	2800 5200

* Dimension with roof

ANTARES: WORKING PLANE	
MODEL	DIMENSIONS X (mm)
ANTARES 26/15	2500x1500
ANTARES 26/28	2500x2800
ANTARES 26/15 TR	(1900x1100) x 2

PRECISION AND REPEATABILITY			
LINEAR AXES*	REFERENCE STROKE	A	R
X/Y	2000 mm	0.031 mm	0.021 mm
Z	1200 mm	0.026 mm	0.019 mm
B	+/- 120°	26 arcsec	
C	360°	16 arcsec	

* Precision with linear scales and direct encoders on PX5 Accuracy (A) and Repeatability (R) on the basis of the ISO-230-2 Regulations

ANTARES WORKING UNITS AND ELECTROSPINDLES						
	CX5 - 8_40	CX5 - 8,5_24	CX5 - 10_24	PX5/HX5 - 12_24	PX5/HX5 - 15_24	PX5/HX5 - 20_24 (synchronous)*
B, C STROKES	B=+/- 120°, C=+/- 360°			B=+/- 120°, C=+/- 270°		
RAPID B, C	10800 °/min			9000°/min		
NOMINAL POWER (S1)	8 kW	8,5 kW	10 kW	12 kW	15 kW	20 kW
MAX POWER	9 kW	10 kW	12 kW	15 kW	17 kW	22,3 kW
MAX RPM	40.000 rpm	24.000 rpm	24.000 rpm	24.000 rpm	24.000 rpm	24.000 rpm
MAX TORQUE	6 Nm	8 Nm	9,5 Nm	12,2 Nm	13,8 Nm	20 Nm
TOOL CHANGER	MANUAL AND AUTOMATIC					
TOOLHOLDER	HSK 32 E	HSK 63 F	HSK 63 F	HSK 63 F	HSK 63 F	HSK 63 A
COOLING	LIQUID					

ANTARES TR: STROKES AND SPEEDS									
MODEL	AXIS STROKES					RAPIDS			
	(mm)			(°)		(m/min)		(°/min)	
	X	Y	Z	B	C	X/Y	Z	B	C
ANTARES 26/15 TR	2600	1500	1000	±120	±270	80	70	9000	

ANTARES: TOOL CHANGER MAGAZINES					
	Standard FOR CX5	Standard FOR PX5	OPTIONS		
N. STATIONS	8 on board	8 on board	additional 8 on board	16 carousel	8 pick up
HOLDER INTERAXES (MM)	100	80	80	117	80
Ø MAX WITHOUT LIMITATION (MM)	90	70	70	110	70
Ø MAX WITH LIMITATION (MM)	250	400	400	230	400
MAX TOOL LENGTH (MM)	265	265	165	300	465*
MAX WEIGHT SINGLE TOOL	3 kg	3 kg	3 kg	6 kg	5 kg

* Values from the spindle nose

CMS connect the IoT platform perfectly integrated with the latest-generation CMS machines

CMS Connect is able to offer customised micro services through the use of IoT Apps that support the daily activities of industry operators - improving the availability and use of machines or systems. The platform displays, analyses and monitors all data from connected machines. The data collected by the machines in real time become useful information increase machine productivity, reduce operating and maintenance costs and cut energy costs.



CMS active a revolutionary interaction with your CMS machine

Cms active is our new interface. The same operator can easily control different machines as the “CMS Active interfaces maintain the same look&feel, icons and iteration approach.



APPLICATIONS

SMART MACHINE: Section designed for the continuous monitoring of machine operation, with information on:

Status: machine status overviews. The representations provided allow machine availability to be checked - to identify possible bottlenecks in the production flow;

Monitoring: instantaneous, live display of the operation of the machine and its components, of currently running programs and potentiometers;

Production: list of machine programs run within a given timeframe with best time and average running time;

Alarms: active and historical warnings.

SMART MAINTENANCE

This section provides a first approach to predictive maintenance by sending notifications when machine components indicate a potentially critical state associated with reaching a certain threshold. In this way, it is possible to take action and schedule maintenance services, without any down-time.

SMART MANAGEMENT

Section designed for KPI presentation for all the machines connected to the platform. The indicators provided assess of the availability, productivity and. The indicators provided assess of the availability,

productivity and efficiency of the machine and the quality of the product.

MAXIMISED SECURITY

CMS Connect uses the standard OPC-UA communication protocol, which guarantees the encryption of data at Edge interface level. CMS Connect's Cloud and DataLake levels meet all state-of-the-art cyber-security requirements. Customer data are encrypted and authenticated to ensure total protection of sensitive information.

ADVANTAGES

- ✓ Optimisation of production performance
- ✓ Diagnostics to support components warranty optimisation
- ✓ Productivity increase and downtime reduction
- ✓ Improvement of quality control
- ✓ Maintenance costs down

EASY OF USE

The new interface has been especially developed and optimized to be immediately used via touch screen. Graphics and icons have been redesigned for user-friendly and comfortable navigation.

ADVANCED ORGANIZATION OF PRODUCTION

Cms Active enables configuring different users with different roles and responsibilities according to the operation mode of the machining centre (e.g.: operator, maintenance man, administrator, ...).

It is also possible to define the work shifts on the machining centre and then survey activities, productivity and events that have occurred in each shift.

ABSOLUTE QUALITY OF THE FINISHED WORKPIECE

With CMS aActive the quality of the finished workpiece is no longer jeopardized by worn-out tools. The new Tool Life Determination system of CMS Active sends warning messages when the tool life is running out and recommends its replacement at the most appropriate time.







TOOL SET-UP? NO PROBLEM!

CMS Active guides the operator during the tool magazine set-up phase, also allowing for the programs to be run.



SERVICE

OUR TECHICIANS BY YOUR SIDE ALL OVER THE WORLD

-  Training
-  Installation
-  Remote Customer Care (RCC)
-  On-site assistance
-  Maintenance
-  Changes & Retrofitting
-  Spare Parts

A GLOBAL PRESENCE

FOR BEST-IN-CLASS SERVICE

- 36,000 different codes to serve machinery of all ages;
- 1 central warehouse at the headquarters in Zogno and 6 bases around the world fully integrated at IT level and controlled by a shipping optimisation software to reduce waiting times;
- 98% of orders available in stock;
- spare parts guaranteed thanks to a scrupulous control process and validation via our internal quality laboratory;
- availability to draw up recommended spare parts lists based on client needs, to reduce down time to a minimum;

THE RANGE OF CMS PLASTIC TECHNOLOGY

FOR PLASTIC PROCESSING

3/5-AXIS CNC MACHINING CENTERS (passage in Z up to 500 mm)



TRACER



TIME



EVOTECH

5-AXIS CNC MACHINING CENTERS (passage in Z from 500 mm)



ATHENA



ANTARES



ARES



GENESI

BEAM SAWS



HELIX

SAWS



T-MAXI

THERMOFORMING MACHINES



EIDOS



BR5 CS



BR5 HP



BR5 SPECIAL SPA



MASTERFORM

WATERJET CUTTING SYSTEMS



TECNOCUT PROLINE



TECNOCUT SMARTLINE



C.M.S. SPA
via A. Locatelli, 123 - 24019 Zogno (BG) - IT
Tel. +39 0345 64111
info@cms.it
cms.it

a company of **scm**group