

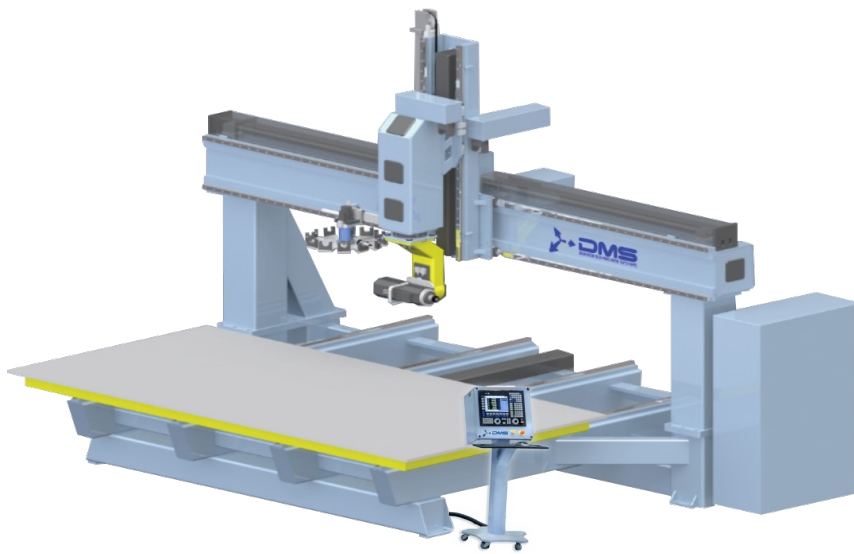

# 5 Axis CNC Machining Centers



## 5 Axis Moving Table Machine

### 10' x 5' Single Table (pictured)

Diversified Machine Systems' 5 Axis Moving Table Machining Centers offers a stationary bridge with moving table design for full 5 axis machining and contouring. These high-precision machines are commonly used for contouring, trimming and drilling processes. For custom sizes & options, please contact the DMS factory.

## Specifications

### Standard Sizes

- Widths
  - 5 feet / 1.5 meters
  - 6 feet / 1.8 meters
  - Twin 5 feet / 1.5 meters

- Depth
  - 5 feet / 1.5 meters
  - 10 feet / 3 meters
  - 12 feet / 3.6 meters

### Standard Features

- Fagor 8055 Controller
- Fagor Sercos Servo Drive System
- 2 Year Warranty on Fagor Components
- 36" Z Axis
- Aluminum Table with 3/8" Inserts on 12" Centers
- 1 1/4" Vacuum Hose Brought to Table
- 460 Volt, 3 Phase Power
- Air Conditioner

### Optional Features

- Fagor 8065 Controller
- 36", 48" or 60" Z Stroke
- Spindle Options from 5 HP - 12 HP
- Continuous C Rotation
- Automatic Lubrication System

### Diversified Machine Systems

1068 Elkton Drive Colorado Springs, CO 80907  
Phone: 719.226.5066 | Fax: 719.226.9810

[www.dmscncrouters.com](http://www.dmscncrouters.com)

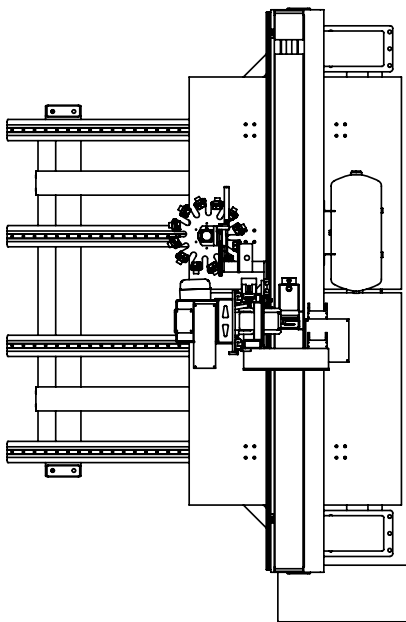
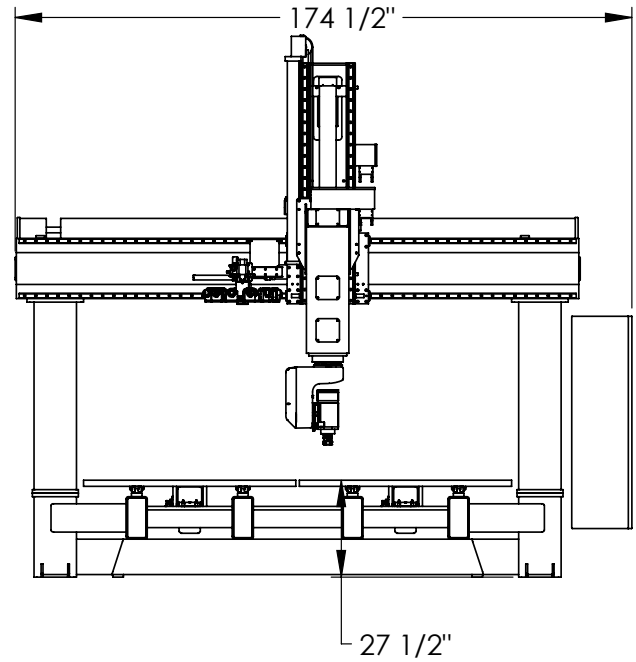
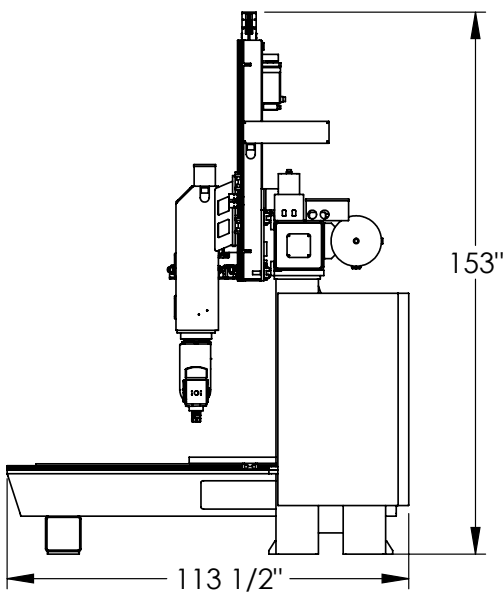

**10'(w) x 5'(d) x 48"(h) Moving Table (pictured)**