

5 Axis Enclosed Overhead Gantry

DMS 12' x 5' x 48" (pictured)

Diversified Machine Systems' 5 Axis Enclosed CNC routers offer the safety & precision required by many industries. Complete in-house steel fabrication & machine assembly assures that each machine is robust, precise and high performing. For custom sizes & additional options, please contact the DMS factory.

Specifications

Standard Sizes

- Widths
 - 7 feet / 2 meters
 - 10 feet / 3 meters
 - 12 feet / 3.6 meters
- Depths
 - 5 feet / 1.5 meters
 - 7 feet / 2 meters

Standard Features

- Fagor 8055 Controller
- Fagor Sercos Drive System with Absolute Encoders on All Linear Axes
- 460 Volt, 3-Phase Power
- Aluminum Table
- Manual Doors
- Enclosed on Four Sides
- 10 Position Tool Rack
- Sealed Electrical Cabinet with A/C
- 48" Z Stroke

Optional Features*

- Fagor 8065 Controller
- Spindle Options from 5 HP - 30 HP
- Retractable Roof Enclosure
- Volumetric Compensation
- Continuous C Rotation
- Automatic Lubrication System
- Linear Feedback Scales
- Absolute Encoders on Rotary Axes
- Extend 1 Year to 2 Year Warranty on Fagor Components



DMS
DIVERSIFIED MACHINE SYSTEMS

5 Axis Enclosed Overhead Gantry Drawing

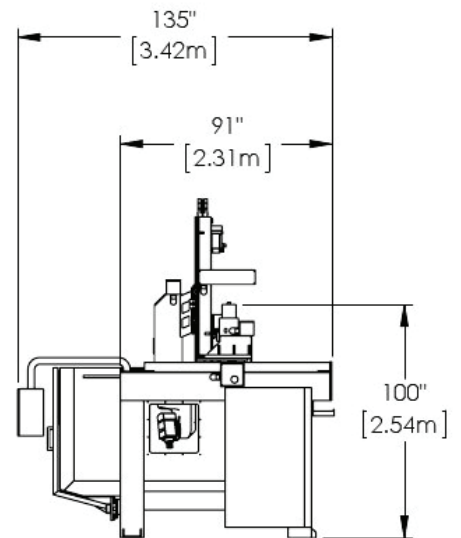
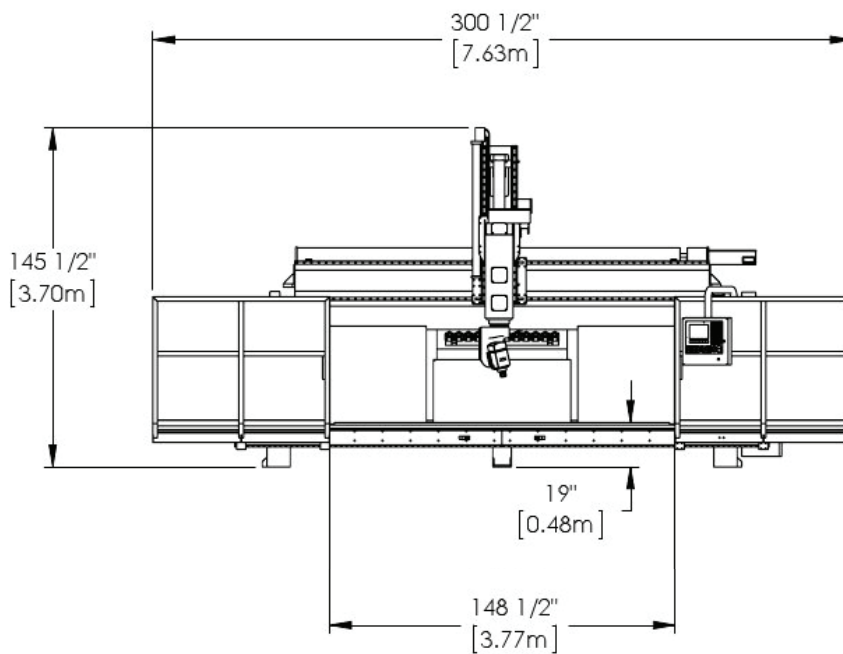
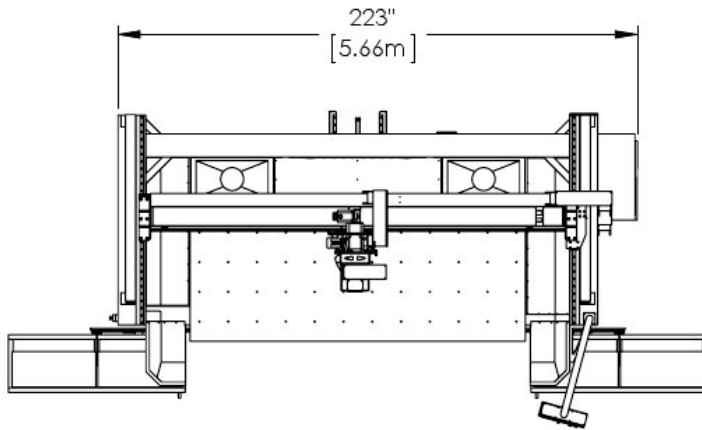

*Contact DMS Sales for a full list of optional features at Sales@DMSCNCRouters.com or 855.266.5064.

DMS 12'(w) x 5'(d) x 48"(h) (pictured)

Diversified Machine Systems

1068 Elkton Drive Colorado Springs, CO 80907
Phone: 855.266.5064 | Fax: 719.226.9810

2014.v5

www.dmsncrouters.com