



5 Axis D5E Overhead Gantry Twin Table Model (pictured)

Diversified Machine Systems machines are equipped with top of the line spindles & tools, a high performance Fagor CNC Controller, precision machine tool positioning components, and Fagor Drive System providing true tool path stability, speed & accuracy. The DMS D5E includes a one year limited warranty.

Specifications

Standard Models

- 4' x 3' Stationary Table
- Twin 2' x 3' Shuttle Tables

Standard Features

- Fagor 8055 Controller
- Fagor Sercos Drive System
- 460 Volt, 3-Phase Power
- 36" x 48" Aluminum Table
- Manual Doors
- 7 HP Double-Ended Spindle
- Sealed Electrical Cabinet with A/C
- 30" Ram Style Z Stroke

Optional Features*

- Fagor 8065 Controller
- Tool Change Spindles
- Automatic Vacuum Valves
- Automatic Tool Changer
- Tool Height Sensor
- Continuous C Rotation
- Automatic Lubrication System
- Roof Enclosure
- Extend 1 Year to 2 Year Warranty on Fagor Components



DMS
DIVERSIFIED MACHINE SYSTEMS

5 Axis D5E Overhead Gantry Drawing

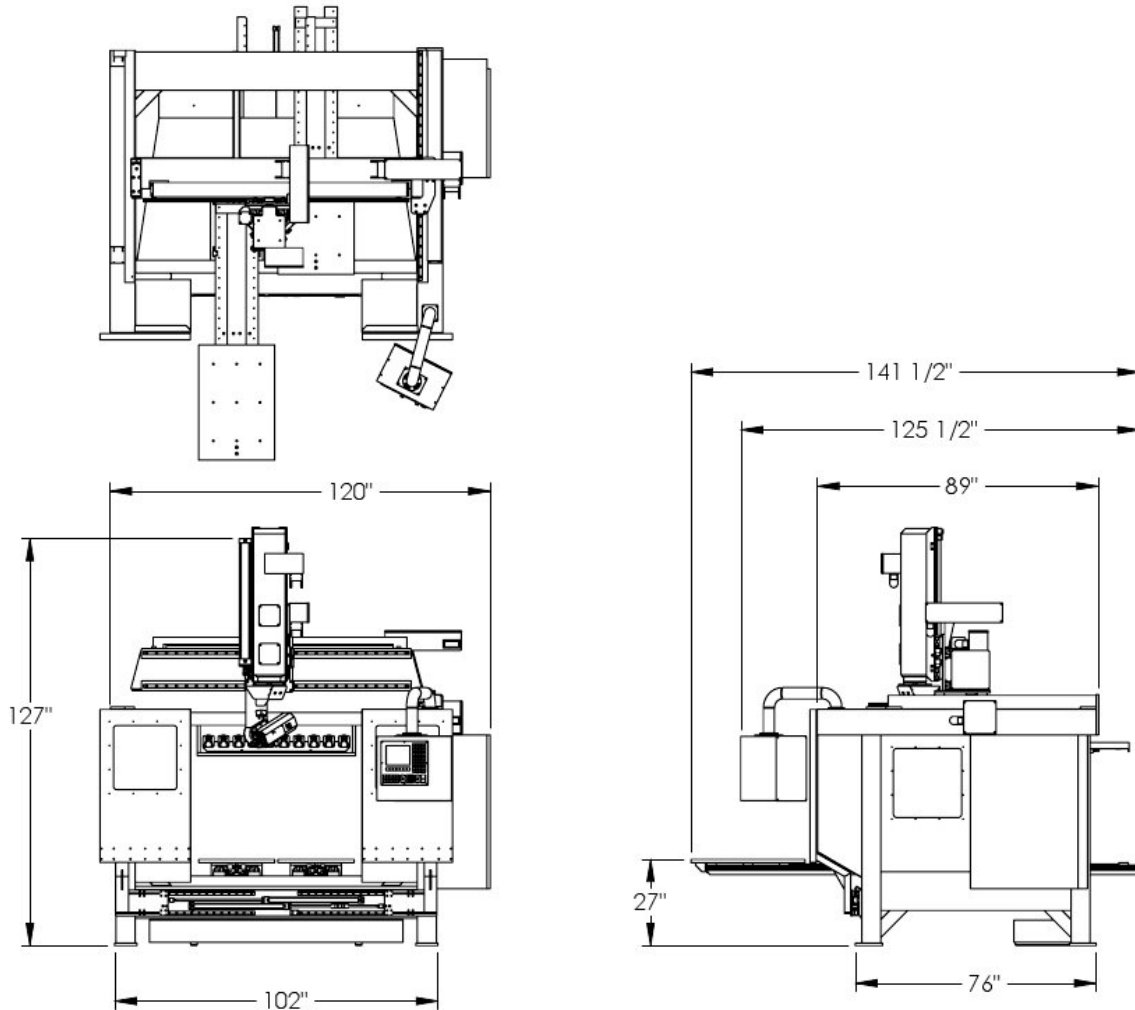

Twin 2'(w) x 3'(d) Table Model (Pictured)

*Contact DMS Sales for a full list of optional features at Sales@DMSCNCRouters.com or 855.266.5064.

Diversified Machine Systems

1068 Elkton Drive Colorado Springs, CO 80907
Phone: 855.266.5064 | Fax: 719.226.9810

2014.v5

www.dmsncrouters.com